

A hat for your 'little chef'.

Make a paper chef's hat and then do some cooking with your child.



Adult supervision is essential when making and playing with home made toys.

Involve and talk with your child as much as possible while creating this activity.

Have a look at *Mummy and Me Cookbook* which has lots of great recipes for you to make with your child.

CHEF'S HAT

You will need:

- a copy of activity template
- crayons, textas, pencils, for decorating
- strip of white paper 10cm x 60cm
- piece of coloured tissue paper 45cm x 45cm approx.
- scissors
- glue
- tape

Instructions

1. Decorate the strip of paper with the pirate pictures provided.
2. Fit the paper strip around your child's head and tape ends together.
3. Use a piece of coloured tissue paper to form the top of the hat (see diagram) and tape to inside of headband. An adult will need to do this as it is quite tricky.

Idea

Make an adult sized hat too.

Maybe you could make some fish shaped biscuits using the recipe for Cut-Out Cookies in the *Mummy and Me Cookbook* by Annabel Karmel.

Pirate decorations for headband

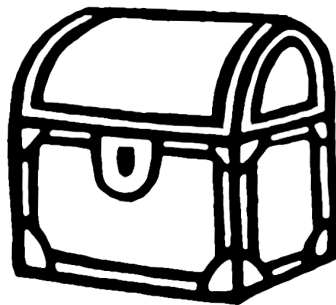
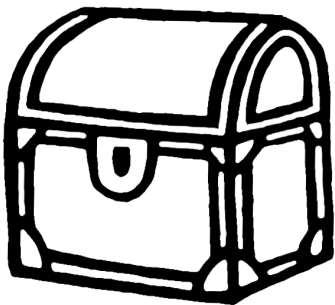
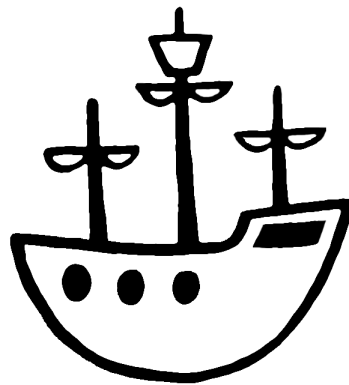
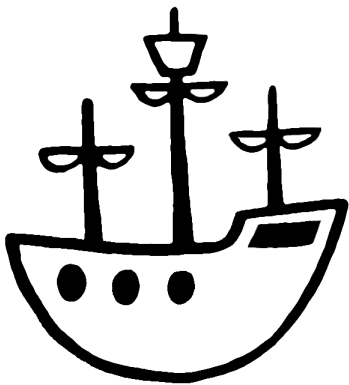
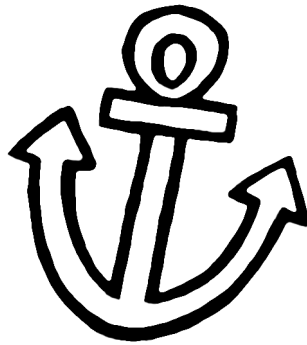
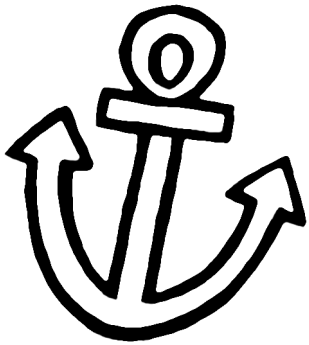

How to make the top of the chef's hat.

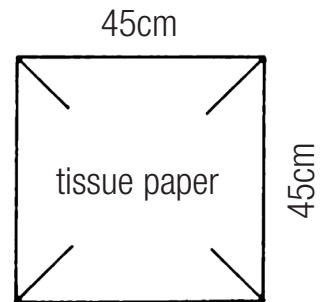

1. Cut four diagonal slits, approximately 15cm.

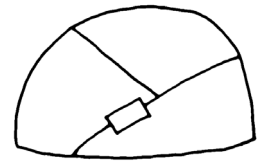
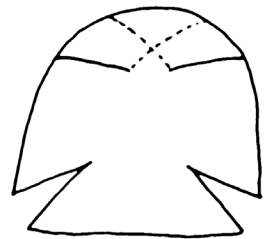

2. Bend the tissue paper into a dome shape by overlapping the corners and tape together.

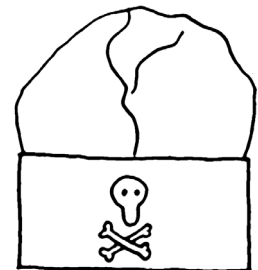

3. Fit the dome into the headband and tape into place.