

Blast Off!

By Shelly Unwin and Ben Wood

Climb aboard the rocket ship and zoom past the eight planets. Two junior astronauts guide the reader through a fun exploration of the solar system in this fact filled story. The rollicking rhyming verse along with the bright and detailed illustrations will engage and excite.

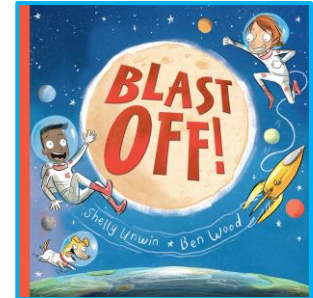

Are you ready? 5, 4, 3, 2, 1...BLAST OFF!!!

Key Message for Parents | Children Are Born Ready To Use and Learn Mathematics

Math is so much more than just numbers and counting. Shapes, colours, size and number are all math concepts and can be introduced in fun and playful ways.

Some ideas to share with parents to help children develop their natural mathematical abilities are;

- Sing nursery rhymes that have numbers, counting and lots of repetition such as *Hickory Dickory Dock* and *Five Little Ducks*
- Read books that incorporate the number concepts within the story like ‘The very hungry caterpillar’. These stories help children understand the purpose of numbers and counting.
- Everyday experiences allow children to explore mathematical concepts. These experiences like getting dressed, eating, cooking and even sorting the washing provide opportunities to count together, sort together and have fun with numbers, shapes and colours
- Collect objects such as toys, blocks, leaves from the garden or books and order into size from smallest to largest.
- Use a range of directional language to build math vocabulary – over, under, above, around

Early Years Learning Framework | Outcome 3: Children Are Confident and Involved Learners

By exploring and following children’s interests we can help them in their learning journey. When children are fully engaged in any activity there is great potential for learning. We can help young children become confident learners by:

- Providing open ended play activities which foster curiosity and engagement
- Allowing time in the day for play, song and stories
- Encouraging them to discuss their ideas and understandings
- Giving praise and recognizing all achievements, big and small.

Find booklists, tip sheets, nursery rhymes and activity and learning time sheets @

thelittlebigbookclub.com.au     



Welcome

Ask carers to write nametags for themselves and their children.

Welcome everyone, introduce yourself, remind adults to turn their mobile phones off and that there will be time for adults to chat after the story and songs.

Welcome Song (or your preferred song)

Have the words available as a handout or written on a board or butcher's paper for the adults to read and join in.

Good Morning

Good morning to you

Good morning to you

Good morning everybody

and welcome to you!



Song

Zoom Zoom Zoom - <https://www.youtube.com/watch?v=tMJ9pZ9W7jc>

Zoom zoom zoom we're going to the moon

Zoom zoom zoom we're going to the moon

If you want to take a trip climb aboard my rocket ship

Zoom zoom zoom we're going to the moon

In 5, 4, 3 2 1 – Blast Off

Far Far far we're going to the stars

Far Far far we're going to the stars

If you want to take a trip climb aboard my rocket ship

Far Far far we're going to the stars

In 5, 4, 3 2 1 – Blast Off

Fun fun fun we're going to the sun

Fun fun fun we're going to the sun

If you want to take a trip climb aboard my rocket ship

Fun fun fun we're going to the sun

In 5, 4, 3 2 1 – Blast Off

Action Tip:

Encourage children to crouch down low and slowly rise up, stretching their bodies until they are on their "tippy toes"





Before Reading

Before starting the book or showing the cover tell the children the title and get them to give suggestions about what the book is about.

Reveal the cover and talk about what is happening. There are 2 people on the cover in special outfits. Ask if anyone knows what they are called- space suit. What type of person wears a space suit- an astronaut!

Open the book to the end papers which show the solar system. Talk about the names of the planets and how they are in a certain order from the sun. Tell the children the story will tell us more about the planets. Ask if anyone knows what the planet we live on is called.

During Reading

Get the children to join in the countdown to blast off. Children can hold up 5 fingers and put a finger down as the countdown happens then blast their arms above their heads.

Along the bottom of each page are small pictures of the eight planets in order with an arrow pointing to the planet that page is about. Highlight this to the children and count the planets that are left to explore.



After Reading

There is a lot of information in the book. See if the children can remember the names of the eight planets. Revisit again and ask which planet we live on.

You might like to re-read the story and focus more on what is happening in the illustrations. Talk about stars and how they form constellations.



The last page in the book has further information about each planet. Ask the children to pick a planet and then share this information included about this planet. Continue with the other planets.

Song

I'm a little rocket

I'm a little rocket, tall and thin (stand straight and tall)

Here is my nose cone (reach arms above head and join hands together into pointed cone)

Here are my fins (hold arm down straight along body and turn hands out to make fins)

When I get all fired up, launch begins (crouch down)

Watch me rise and see me spin – (jump into the air and spin around)



Activity Time

Rocket zooming around the moon

What you need

- Rocket template
- Paper plate
- Split pin
- Colouring pencils or paint
- scissors
- crepe paper

What to do:

1. Copy the rocket template onto cardboard
2. Colour and decorate the rocket
3. Cut out the rocket
4. Attach crepe paper to the end of the rocket for flames
5. Colour/paint the paper plate to look like a moon (optional – decorate the paper plate to be a planet. Allow your imagination to soar)
6. Make a small hole in the middle of the paper plate
7. Using the split pin attach the rocket to the back of the paper plate
8. Fly your rocket around the moon.

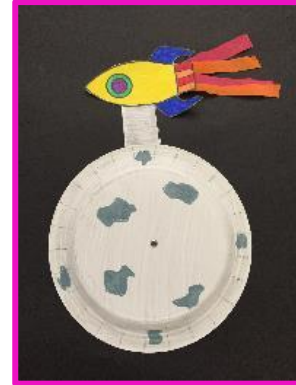

Extension Activity:

- Get the children up and moving by doing a *Galaxy Stretch* and reaching for stars
- You will need some stars pictures printed on card or laminated with Velcro dots attached to the back and a felt board.
- As the children are stretching, walk around the group with the stars and hold one above each child's head as they reach up high. Once everyone has a star they come up to the felt board and stick their star on it to make a large constellation.
- If there is a large group, hand stars to the parents to hold above their child's head

Rhyme to sing

Bend and stretch, reach for the stars --- children bend down then reach up high

There goes Jupiter, here comes Mars --- point in the air at the planets

Bend and stretch reach for the sky

Stand on tippy toes, oh so high --- reach up high on tippy toes to catch a star

STEM

Space is a fantastic topic to explore with young children. The night sky captures a child's imagination as they gaze at the stars. This can spark a conversation about how a group of stars is called a constellation and these make certain patterns in the sky.

A simple activity to explore this concept with young children is to build a constellation with some marshmallows and toothpicks.



Source: <http://www.simplyrealmoms.com/posts/simple-summer-school-constellations/>



Goodbye

Conclude the session with some suggestions of books that parents might want to share with their children. The Little Big Book Club suggests the following books to support learning in this area. If your library has copies, make them available for families to borrow or include them in your story time session.

For some more stories to share, we recommend the following titles:

- **Roaring Rockets** by Tony Mitton and Ant Parker
- **Maisy's Moon Landing** by Lucy Cousins
- **How to Catch a Star** by Oliver Jeffers

Goodbye Song

Depending on the size of your group, you may wish to insert each child's name in the place of 'you' as it develops a more personal relationship between yourself, the child and the family.

Sung to the tune of (Here We Go Round the Mulberry Bush) or your choice.

Goodbye

This is the way we say goodbye (wave) say goodbye, say goodbye

This is the way we say goodbye to all our library friends (or) (to our friend.....)!



Rocket Ship Template

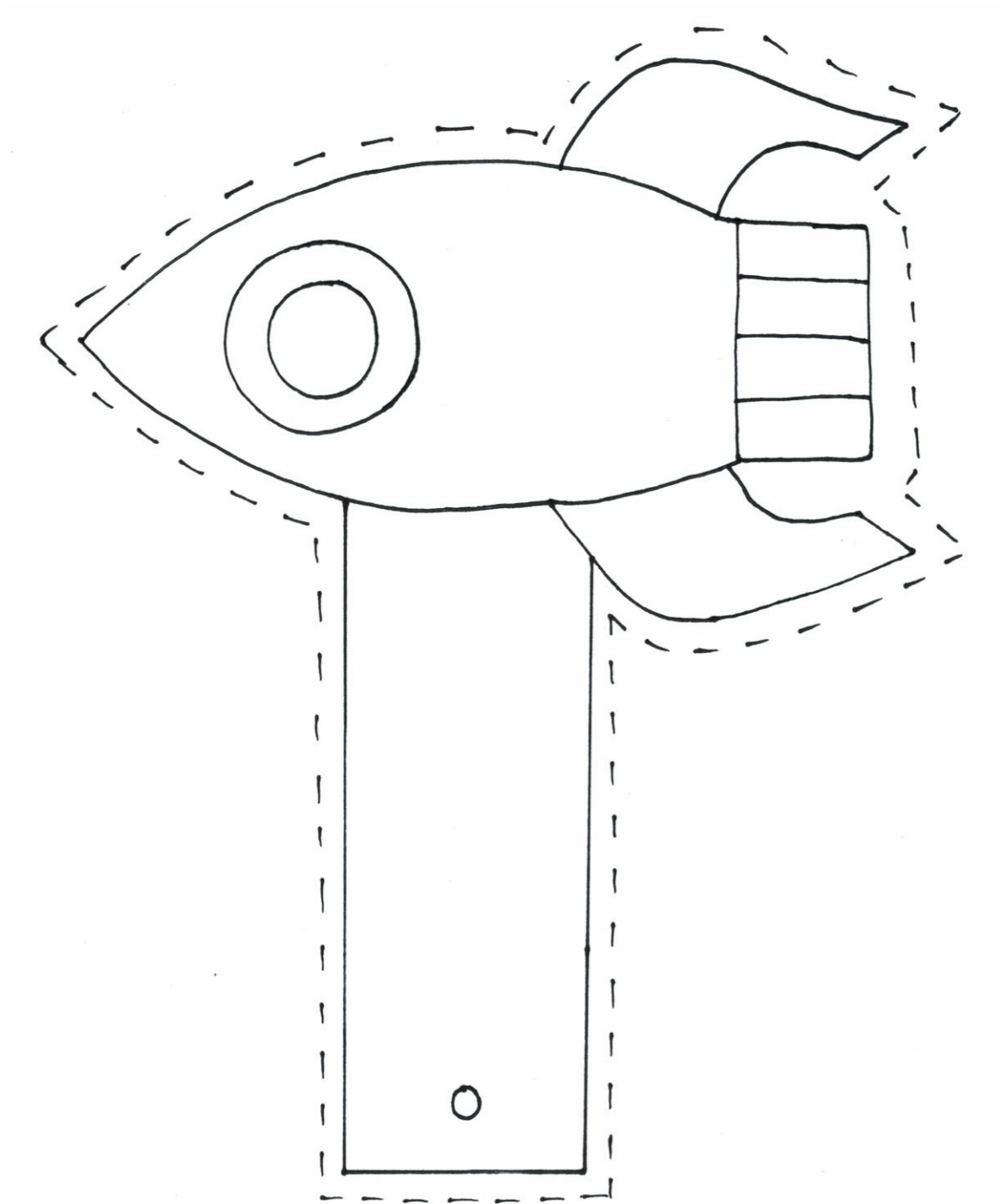

1. Colour in rocket
2. Cut around dotted line
3. Secure to paper plate moon with a split pin